

The Engineer's Thumb – Compressor

ValveWizard PCB User Guide (First issue PCBs)

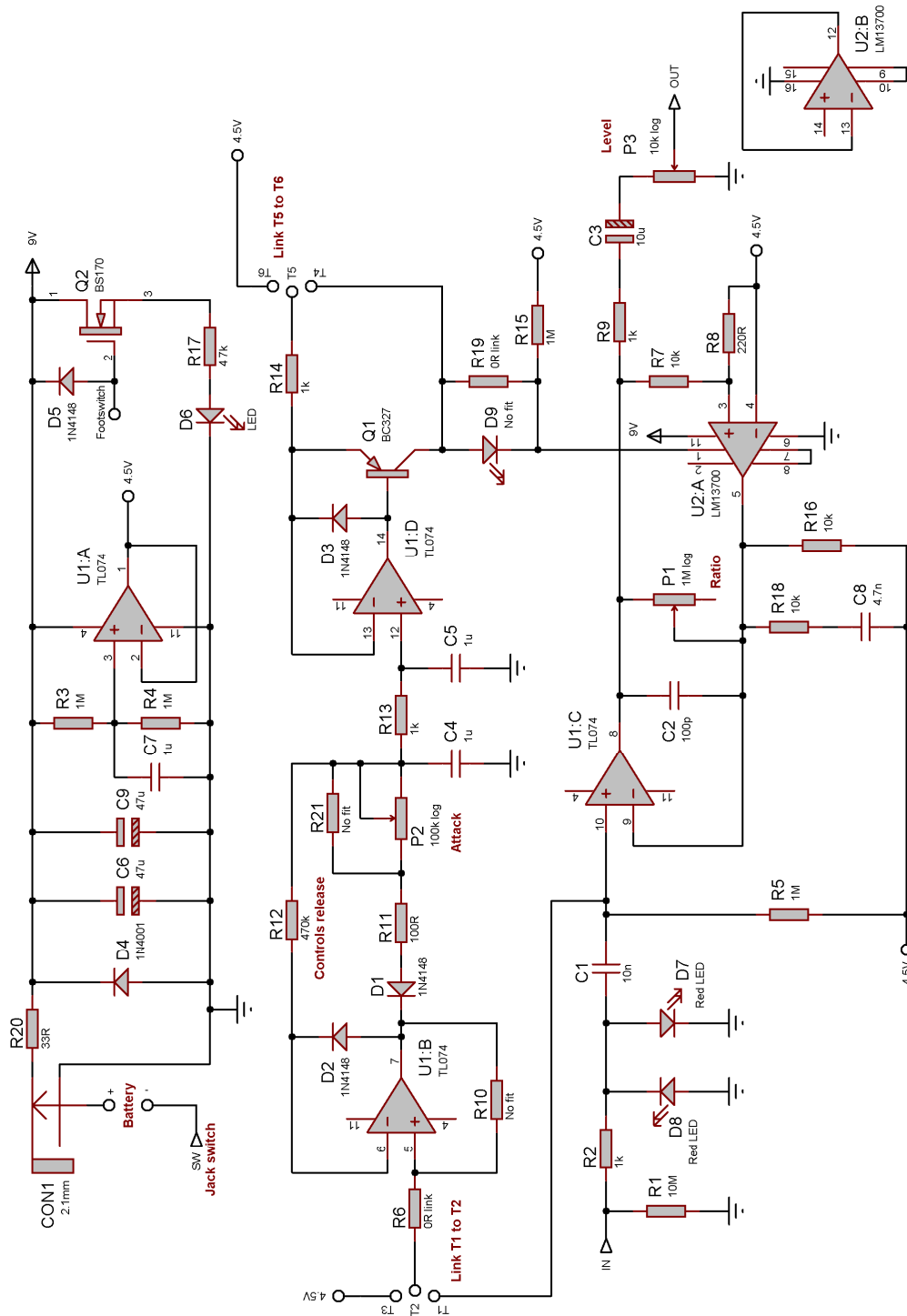

Fig. 1: Circuit schematic

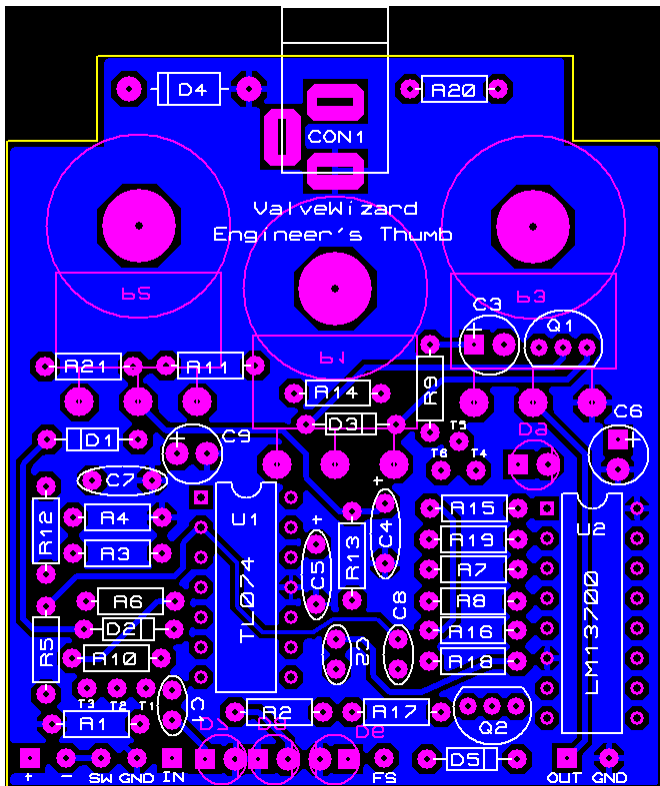

Fig. 2: Component layout

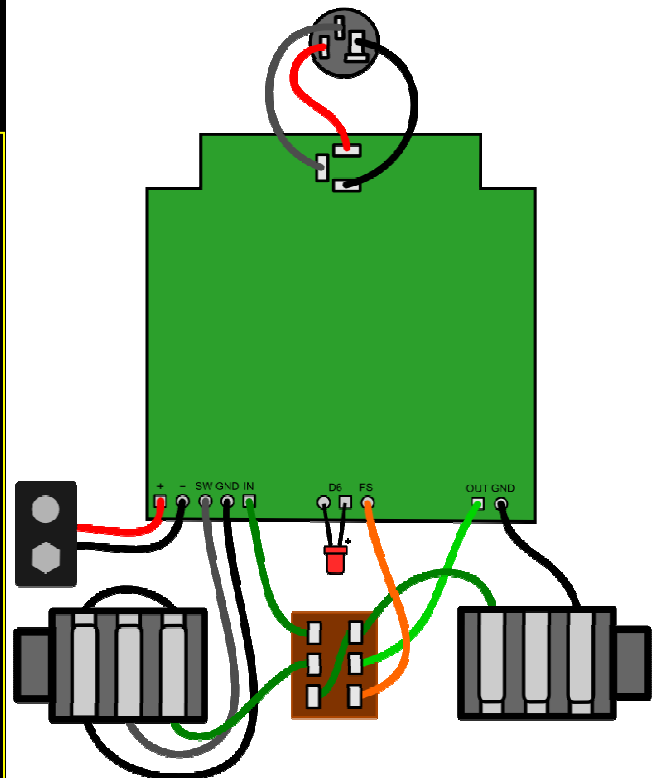

Fig. 3: Wiring diagram (with millennium bypass)

Before populating the PCB you can use it as a drill template by poking a pen through the holes where the pots are.

Populate the smallest components first, e.g. diodes and resistors. Best soldering practice is to tack-solder the component in place so it does not fall out, then snip off the excess leads. Then re-solder the joints properly. This ensures the cut ends will be fully coated in solder. Failure to do this will leave exposed copper that will oxidise over time.

It is recommended that you use IC sockets for the chips.

The square solder pads for the LEDs are the *anodes* (e.g. positive, long lead). Note: D7 and D8 *do not* visibly light up, they just provide graceful clipping if the input is overloaded.

Don't forget to link the pads labelled T1 and T2, and also T5 and T6.

Parts list:

	Value	Notes
R1	10M	Any value 1M to 10M will do
R2	1k	
R3	1M	
R4	1M	
R5	1M	
R6	0R	Wire link
R7	10k	
R8	220R	
R9	1k	
R10	-	Not fitted
R11	100R	
R12	470k	Reduce for faster release
R13	1k	
R14	1k	
R15	1M	
R16	10k	
R17	4.7k	Reduce for brighter indicator LED
R18	10k	Optional treble boost
R19	0R	Wire link
R20	33R	Fusible/flameproof preferred
R21	-	Not fitted

C1	10n	Reduce for bass cut, e.g. 1n
C2	100p	
C3	10u	Up to 47u will do
C4	1u	Plastic or tantalum preferred
C5	1u	Plastic or tantalum preferred
C6	47u	Up to 100u will do
C7	1u	100n to 2.2u will do
C8	4.7n	Optional treble boost
C9	47u	Up to 100u will do

D1	1N4148	
D2	1N4148	
D3	1N4148	
D4	1N4001	Or any power diode
D5	1N4148	
D6	LED	Any indicator LED
D7	Red LED	Use only cheap red GaAs 3mm LED
D8	Red LED	Use only cheap red GaAs 3mm LED
D9	-	Not fitted

P1	1M log	RATIO
P2	100k log	ATTACK
P3	10k log	VOLUME

Q1	BC327	Or any general purpose PNP e.g. BC558
Q2	BS170	Or VN2222 if turned 180 degrees

U1	TL074	Or TL064/TL084/TLE2074
U2	LM13700	Or LM13600

CON1	2.1mm DC jack	
-------------	---------------	--

Link T1 to T2
Link T5 to T6

Labelled solder pads:

+	Battery '+' terminal
-	Battery '-' terminal
SW	Input jack 'ring' terminal (switches the battery on when a cable is plugged in)
GND	Ground
IN	Signal input
FS	Footswitch connection for millennium bypass
OUT	Signal output
GND	Ground

Idle voltages (with 9V supply):

Pin No.	U1: TL074	U2: LM13700
1	4.4V	1.1V
2	4.4V	0V
3	<4.4V (depends on meter impedance)	4.4V
4	8.8V	4.4V
5	<4.4V (depends on meter impedance)	4.4V
6	4.4V	0V
7	4.4V	0V
8	4.4V	0V
9	4.4V	0V
10	<4.4V (depends on meter impedance)	0V
11	0V	8.8V
12	<4.4V (depends on meter impedance)	0V
13	4.4V	0V
14	3.9V	0V
15		0V
16		0V

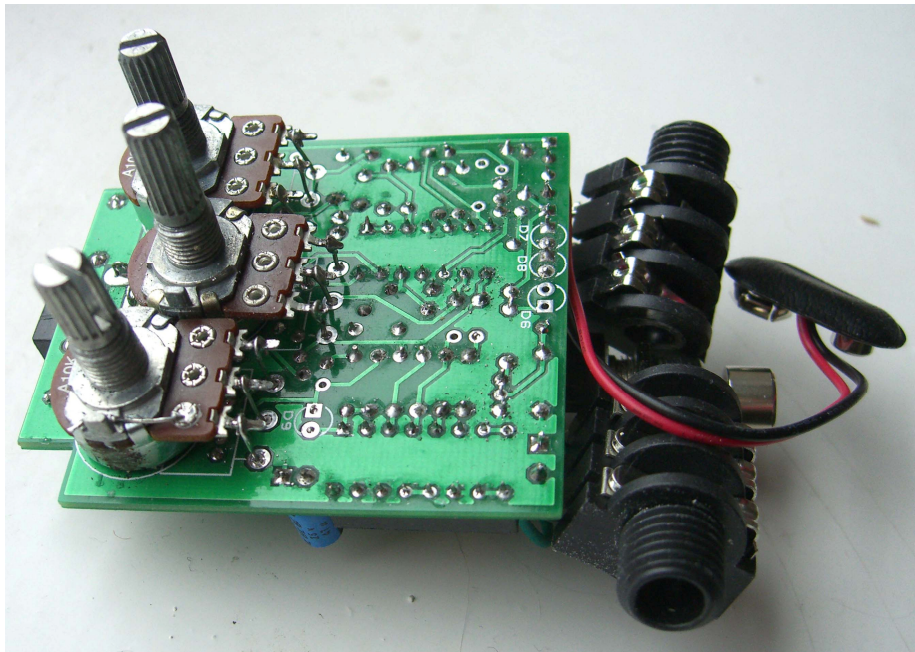

Fig. 4: Pot mounting

Attach some double-sided sticky pads to the backs of the pots. Mount the pots in the enclosure, then lower the PCB onto the backs of the pots and press until firmly stuck. You can now remove the assembly and solder wires from the pot pins to the corresponding solder pads on the PCB.

If you use non-insulated jack sockets then you will need to provide some other method of grounding the metal enclosure. In the photo above you can see I soldered a piece of wire to the anticlockwise pin of the Level pot. This wire makes contact with the enclosure and gets clamped when the pot nut is tightened (I removed the paint from the enclosure where the contact is made).

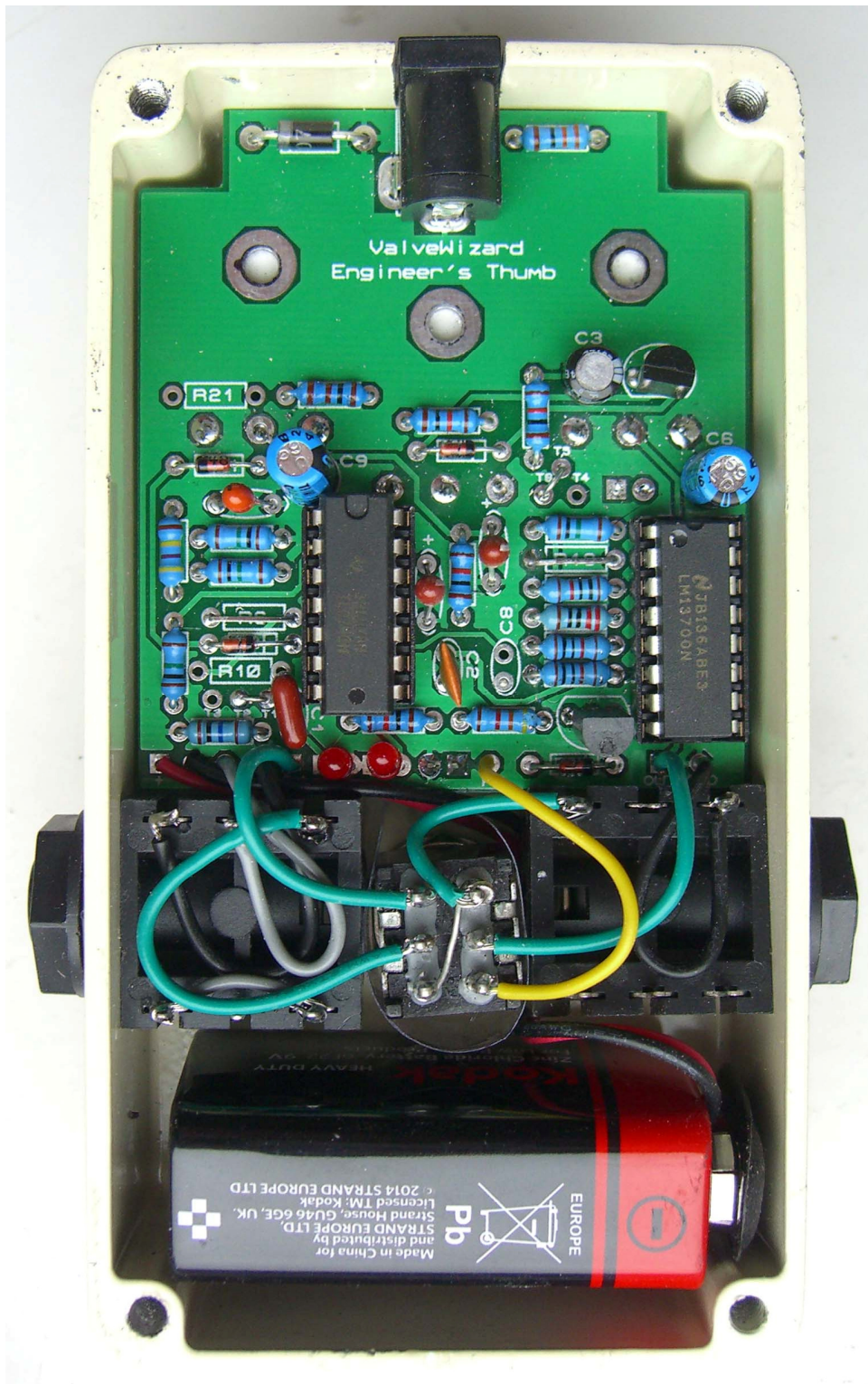

Fig. 5: Close-up of the populated PCB

I had to cut off the 'pip' from the ends of the Cliff jacks. I also wrapped a strip of plastic around the footswitch to stop the jack plugs from touching it.

Dynamic Performance:

The following images were captured by feeding the compressor with a 15mV_{pp} 800Hz signal (below threshold) which is interrupted by a 150mV_{pp} burst (well above threshold). Ratio and Level were set to maximum.

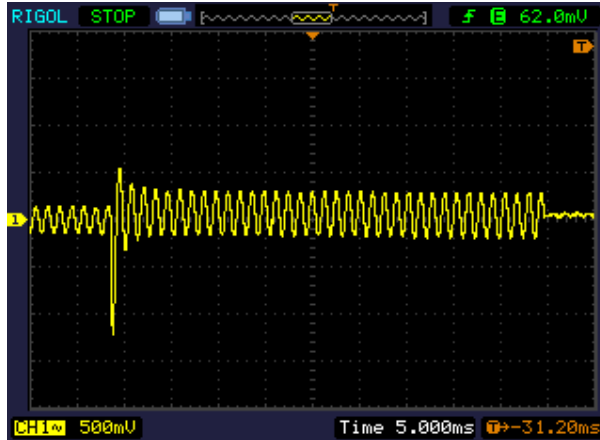

Fig. 6: Fast attack

With the Attack control set to minimum you can see the compressor clamping down on the signal within 3 milliseconds. For guitar this is almost instant, making notes sound more uniform and fluid.

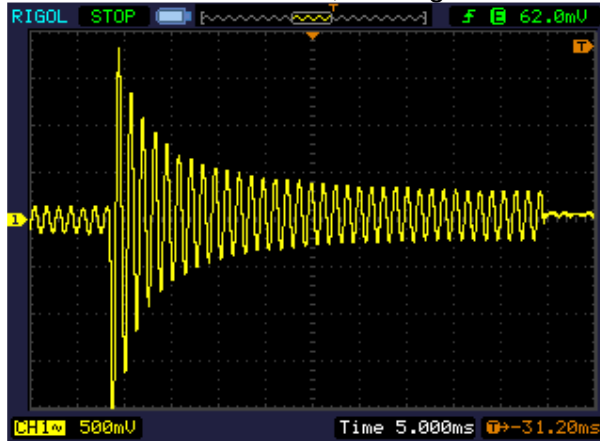

Fig. 7: Slow attack

With the attack control set to maximum the attack time is about 20 milliseconds. This allows note runs to retain their normal dynamics; only with sustained chords will compression kick in.

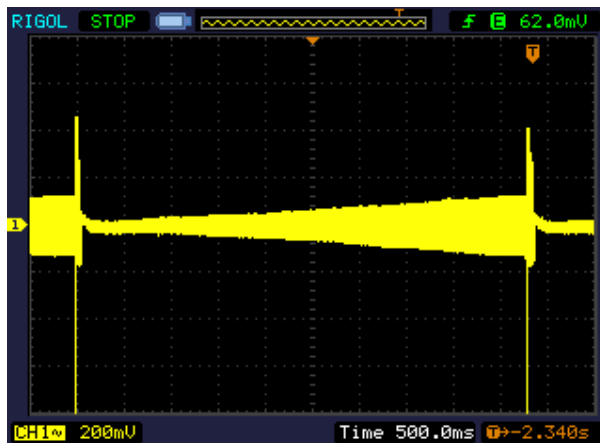

Fig. 8: Release

The stock values give a release time of about four seconds, for maximum sustain on ringing notes. However, you or your guitar may prefer a shorter release by reducing R12 to as little as $100\text{k}\Omega$.